



New

PANAMATIC[®]

Maxi & Maxi Plus Series

Washer Disinfectors

In busy sluiceroom situations, the Panamatic Maxis excel. Their large wash chamber accommodates with ease three round or two square commode pots per cycle. Exceptional capacity is concealed within a surprisingly compact frame.

Maxi Plus: This top of the range Panamatic combines the superior capacity and versatility of the Maxi with a number of other useful features. Its special rimflush facility is particularly useful for disposal functions such as emptying buckets or flower vases. Simply press the foot pedal with the lid open and contents emptied into the chamber are flushed away.





Exceptional Capacity



Hands-free Opening



Easier Loading



Greater Versatility

PANAMATIC®

Maxi & Maxi Plus Series

Washer Disinfectors

Large Capacity:

- | | | |
|------------------------|-----------------------|-------------------|
| Round Commode & Lid: 3 | Oval Commode & Lid: 2 | Square Commode: 2 |
| Bed pan: 2 | Slipper pan: 2 | Urine bottle: 3 |
| Catheter jug: 3 | Wash bowl: 2 | Bucket: 1 |
| Toilet seat raiser: 1 | | |

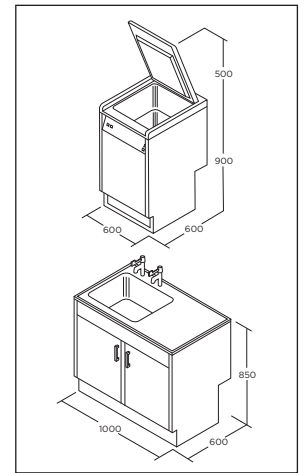

Panamatic Combis

Panamatic Combis combine a Panamatic with a stainless steel sink unit complete with wrist lever taps, work surface and lockable storage cupboard.

Combi sink units are available in a choice of single or double door sizes and can be combined with any Panamatic in the range. The modular design adopted makes it possible to combine these units with other products in Dolphin's range, (including Incomatic macerators and Hygenex disposal hoppers) to give a neat and entirely uniform appearance to your sluiceroom.

STANDARD FEATURES

- Hands free lid opening**
- Drain blockage cut-out**
- Digital temperature display**
- Cycle counter**
- Two year warranty**

Performance:

Disinfection - a minimum of 80°C for one minute as required by all current British Standards (adjustable should Standards change in the future); Cycle time approximately 5 minutes Electrical Consumption 0.15kW per cycle Water Consumption 20-25 litres per cycle.

After Sales Service

Once your Panamatic has been installed, our service engineers will call to commission and ensure that each machine conforms to the exacting standards demanded by our quality systems. We will train your staff how to use your Panamatic and look after it properly. During the 2 year warranty, technical support is provided by our own specialist and highly skilled engineers. At the end of the warranty period, we offer you a choice of service contracts to keep your Panamatic working at its best.



DDC Dolphin Ltd

The Fulcrum, Vantage Way
 Poole, Dorset BH12 4NU
 tel: **01202 731555** | fax: 01202 731666
 info@ddcdolphin.co.uk

DDC Dolphin, Panamatic are Registered Trade Marks